



Field Modification FM22007

VS2.5 (3 PS): Replacing UG69* and NAPS43* with UG132 and NAPS58A

Issue 1.0 11 January 2023

Nautel Limited

10089 Peggy's Cove Road,
Hackett's Cove, NS, Canada B3Z 3J4
T.877 6 nautel (628835) or +1.902.823.2233
F.+1.902.823.3183 info@nautel.com

U.S. customers please contact:

Nautel Inc.

201 Target Industrial Circle, Bangor ME 04401
T.877 6 nautel (628835) or +1.207.947.8200
F.+1.207.947.3693 info@nautel.com

e-mail: support@nautel.com

www.nautel.com

FM22007 – VS2.5 (3 PS): Replacing UG69* and NAPS43* with UG132 and NAPS58A

FIELD MODIFICATION

1 INTRODUCTION

This document provides instructions for customers to replace the three UG69* Power Supply Modules and NAPS43* Power Supply Distribution PWB with two UG132 Power Supply Modules and NAPS58A Power Supply Distribution PWB in a VS2.5 transmitter.

1.1 Reason for Modification

The UG69* Power Supply Module is no longer available. This modification allows the customer to use a UG132 Power Supply Module in its place.

NOTE

The NAPS43 Power Supply Distribution PWB is not compatible with the UG132 Power Supply Module. The NAPS43* is replaced with NAPS58A.*

1.2 Equipment Affected

This procedure applies to all VS2.5 transmitters with three (3) UG69* Power Supply Modules and an NAPS43* Power Distribution PWB (NARF66F and NARF66F/01 or earlier, NARF66G, NARF66H). Once upgraded the VS2.5 transmitter will require VS SW 5.3.2 or later.

NOTE

To facilitate the modification, Nautel recommends you confirm that your software version is compliant with the requirement in paragraph 1.2, or that you contact Nautel (support@nautel.com) in advance to ensure you have the necessary files and instructions.

1.3 Responsibility for Implementation of Procedure

This modification is written for qualified transmitter maintenance personnel who are familiar with the VS2.5 transmitter.

1.4 Scheduling

Implement this modification at the convenience of station maintenance personnel. The transmitter must be off-air (RF off) during this procedure.

1.5 Manpower Requirements

This procedure requires approximately three (3) hours to complete. Nautel recommends that two (2) people be used to move the transmitter to a suitable work bench, when instructed.

1.6 Tools, Test Equipment and Documentation

- Standard # 1 and # 2 Phillips screwdrivers
- 5-mm nut driver
- 5.5-mm nut driver
- 6-mm nut driver
- Nautel Part # HAS78 push lever removal tool (in the transmitter's ancillary kit)
- Slip-jaw pliers (4 - 6 inch)
- Torque screwdriver (capable of 20 inch-pounds)
- Side cutters
- Isopropyl alcohol
- VS2.5 Troubleshooting Manual (PDF on USB or printed copy)
- IS22001 document (see http://www3.nautel.com/pub/VS_Series/VS_SW_5.3.2/)



1.7 Material Required

The parts required for this modification are contained in the provided Field Modification Kit (Nautel Part # 211-5113, see Table 1).

Table 1: Field Mod Kit, VS2.5 (3 PS), UG69 to UG132 Upgrade (Nautel Part # 211-5113)

Item	Qty	Component	Part #/Description
2	1	211-5161	QR Code Sheet
3	1	211-5318	Power Supply Mounting Deck
4	2	UG132	Power Supply, 18-53Vdc, 47A, 2250W/1200W, 90-265Vac, CC
5	1	NAPS58A	Power Supply Distribution PWB, VS2.5 (UG132)
6	0	-	Not Used
7	1	211-5314	Front Support Bracket Assy w/Foam, VS2.5
8	2	211-5315	Rear Support Bracket Assy w/Foam, VS2.5
9	5	HT77	Tyrap, 0.098 W x 3.9 lg, Black, Heat Stabilized, 115C
10	5	HAC61	Tyrap, Mount, Snap, .187" Hole
11	2	HT79	Tyrap .190W x 7.4 lg, Black, Heat Stabilized, 115C
12	1	211-5317	Hardware Kit, VS2.5 UG132 Upgrade

NOTE

The Field Modification Kit (Nautel Part # 211-5113) contains replacement tyrap and tyrap mounts to allow re-dressing of wires. Use as directed and as desired.

The Hardware Kit (Nautel Part # 211-5317) contains hardware that is referenced throughout this procedure. Additional hardware is provided; some may not be required.

1.8 Publications Affected

Two of the three Power Supply Modules (U1 and U3) have been changed from Nautel Part # UG69* to UG132. The middle Power Supply Module (U2) is no longer required. The Power Supply Distribution PWB (A2) has been changed from Nautel Part # NAPS43* to NAPS58A. Note the following changes that affect the technical documentation:

Operations and Maintenance Manual:

- Section 1 – Description
 - Ac-Dc Power Stage paragraph:
 - Power Supply Modules paragraph: Output voltage range changes from 'between 7 and 53 V' to 'between 18 and 53 V'
 - Figure 1.1 Block Diagram: PA Power Supply output changes to +18-53 VDC
- Section 2 – Operating
 - Figure 2.55 (PA Volts screen and supporting text): Output voltage range changes from 6 to 53 V to 18 to 53 V

Troubleshooting Manual:

- Section 3 – Parts Lists, Family VS Family Tree (Figure 3.1):
 - NAPS43* part number reference in the A2 block changes to NAPS58A.
 - UG69* part number references in the U1 and U3 blocks change to UG132.







- Section 5 – Electrical Schematics:
 - In Table 5-1, the NAPS43* references for SD-4 and SD-5 change to NAPS58A.
 - Electrical schematic SD-1: note that Power Supply Module U2 is not used.
 - Electrical Schematics SD-4 and SD-5 change to the schematics (SD-4, SD-5, SD-5A and SD-5B) attached to this document.

- Section 6 – Mechanical Drawings:
 - In Table 6-1, the NAPS43A and /01 reference for MD-4 changes to NAPS58A.
 - Mechanical Drawing MD-4 changes to the MD-4 drawing attached to this document.

The front panel interface for each Power Supply Module differs as shown in Table 2.

Table 2: Power Supply Module Interface – UG69* (old) Versus UG132 (new)

FRONT PANEL ITEM	UG69* (OLD PS MODULE)	UG132 (NEW PS MODULE)
AC OK LED 	LED is green when the supply's ac input is greater than 175 V ac. LED is off when the supply's ac input is less than 175 V ac.	LED is green when the supply's ac input is greater than 175 V ac. LED is off when the supply's ac input is less than 90 V ac.
DC OK LED 	LED is green when the supply's dc output is within operational limits. LED is off when the supply's output is outside operational limits or inhibited.	Same operation as UG69*.
SERVICE LED 	Not applicable	Power Supply Module is experiencing a thermal alarm (5 °C before shutdown) or thermal shutdown condition.
FAULT LED 	Not applicable	Power Supply Module is experiencing an internal/communication fault such as: thermal shutdown or defective fan, blown Ac fuse or over-voltage shutdown.

1.9 Identification of Modified Assemblies/Parts

Identifying modified assemblies informs future maintainers of the current configuration. Mark the transmitter with “**FM22007**” next to the serial number label using indelible ink to indicate it has been modified.

2 UG69* POWER SUPPLY MODULE/NAPS43* POWER SUPPLY DISTRIBUTION PWB REMOVAL

- (a) Set the transmitter to an RF off state.
- (b) Switch off ac power to the transmitter using the switch on the rear panel of the transmitter.
- (c) Unplug all connections from the transmitter, remove the transmitter from its cabinet and place the transmitter on a suitable workbench.

Refer to Figure 1 and Mechanical Drawings MD-1 and MD-4 in Section 6 of the VS2.5's Troubleshooting Manual for reference.

NOTE

The NAPE87 Exciter/Control PWB and associated exciter deck need to be temporarily removed to access/replace the Power Supply Distribution PWB.*

Partial top view, cover removed for clarity

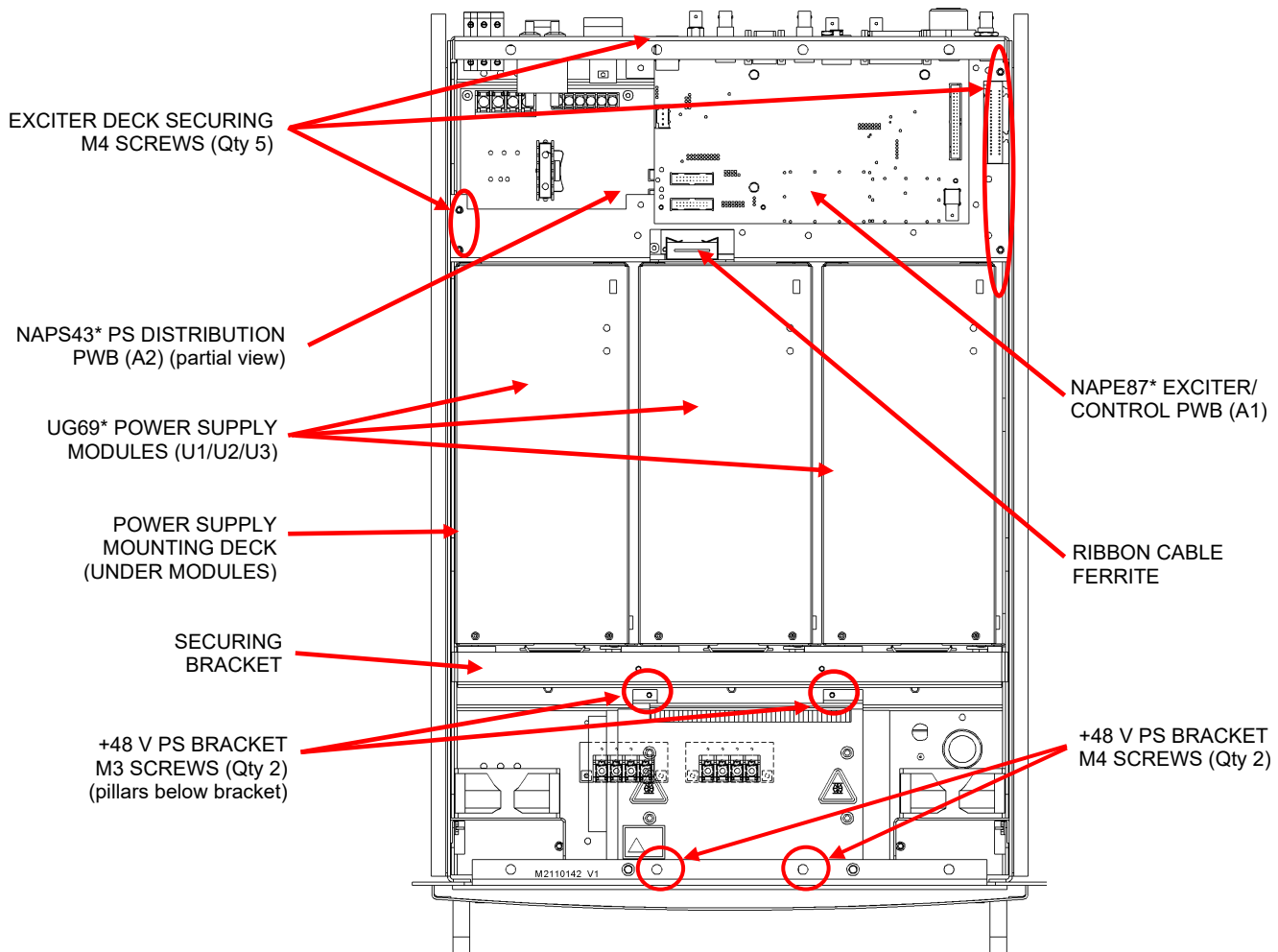

Figure 1: VS2.5 Top View with NAPS53 and UG69s

2.1 Power Supply Module and Exciter/Control PWB Removal

- (a) Remove the VS2.5's top cover and retain hardware.
- (b) Remove the securing bracket from the front of the Power Supply Modules (U1 to U3) by removing the two (2) M3 screws in the top of the bracket (see Figure 1) and the two (2) M4 countersunk screws in each side of the transmitter chassis. Discard bracket and retain hardware.
- (c) Slide the Power Supply Modules toward the front of the transmitter to disengage them from their mating connectors.
- (d) Remove the Power Supply Modules from the transmitter. If desired, retain any functional Power Supply Modules as spares for other transmitters that use UG69* modules. Discard defective Power Supply Modules as per local electronics waste management policies (if applicable).

CAUTION!

The Exciter/Control PWB is static sensitive. Handle it in a static protected manner.

- (e) Remove and retain the Exciter/Control PWB (A1), following the steps outlined in Section 1 of the VS2.5 Troubleshooting Manual. If an Orban Inside card is installed on the Exciter/Control PWB, it can remain secured to the Exciter/Control PWB.
- (f) Remove and retain the five M4 screws that secure the Exciter Deck (see Figure 1).
- (g) Before removing the Exciter Deck, ensure that the exciter wiring and associated items are clear of the Power Supply Distribution PWB and Exciter Deck, cutting tyraps if necessary. Cut the tyrap around the Ribbon Cable Ferrite (see Figure 1) to move the ribbon cables clear of the Exciter Deck and be careful in the following step not to damage the ferrite. Cut the adhesive tape that secures the Ribbon Cable Ferrite bracket to the Exciter Deck. Retain the adhesive tape for re-installation.
- (h) Pull the deck up and forward, and pop out all tyrap anchors, using pliers to pinch the back side of the anchors and push out the hole. Note their locations and orientation for re-installation. Retain the exciter deck for re-installation. Replacement tyrap anchors (Nautel Part # HAC61) are provided in the Field Modification Kit if any are damaged.

2.2 Power Supply Distribution PWB and Mounting Deck Removal

- (a) Disconnect ribbon cables W2P2 and W4P2 and MTA connectors P7 and P8 from the Power Supply Distribution PWB (A2).
- (b) Remove and retain the cover over terminal blocks TB1 and TB2. It is secured with two M3 screws.
- (c) Identify and record the 17 wires (# 7 through 14 and 25 through 33) connected to terminal blocks TB1 through TB4 and note their specific mating points. Remove these wires. Note that wiring destinations are also listed in Table 4.3, Wiring List – VS2.5 Transmitter of the Troubleshooting Manual.
- (d) Remove the hardware that secures the Power Supply Distribution PWB to the transmitter, using a 5.5-mm nut driver for ten M3 nuts, split and flat washers, and a 6-mm nut driver for two pillars near TB1 and TB2. Remove the Power Supply Distribution PWB. If desired, retain the PWB as a spare for other VS2.5 transmitters that use this PWB. Retain hardware for re-installation.



- (e) Remove the 12 M3 countersunk screws that secure the Power Supply Mounting Deck to the transmitter chassis (see Figure 1 to locate the Power Supply Mounting Deck and see Figure 3 for securing hardware location). Retain hardware for re-installation.
- (f) See Figure 1. Remove and retain the two M3 screws securing the +48 V Power Supply Mounting Bracket to the Power Supply Mounting Deck. Remove and retain the two countersunk M4 screws securing the +48 V Power Mounting Bracket, from just above the front panel, and carefully reposition the +48V PS Mounting Bracket to allow access to the two (2) pillars under the M3 screws. Take care to ensure the +48 V Power Supply's wiring is not damaged.
- (g) Use a 6-mm nut driver to remove the two (2) pillars accessed in step (f). Retain pillars for re-installation. Remove and discard the M3 star washers under the pillars.
- (h) Carefully remove the Power Supply Mounting Deck from the transmitter. Before discarding the Power Supply Mounting Deck, remove and retain 12 pillars and flat washers from the mounting studs and the chafe rail along the rear edge. Leave the +48 V Power Mounting Bracket disconnected to allow installation of the new Power Supply Mounting Deck in section 3.

3 UG132 POWER SUPPLY MODULE/NAPS58A POWER SUPPLY DISTRIBUTION PWB INSTALLATION

Refer to Figures 2, 3 and the attached Mechanical Drawing MD-4 for reference.

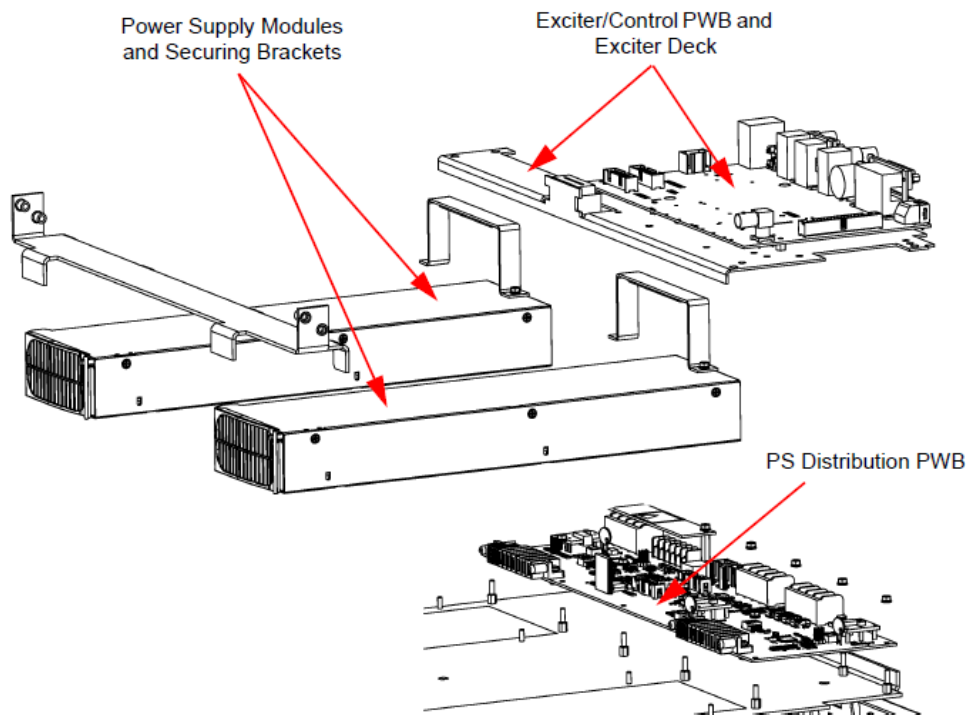

Figure 2: Orientation of Installed Items – Exploded View

3.1 Mounting Deck and Power Supply Distribution PWB Installation

CAUTION!

The Power Supply Distribution PWB is static sensitive. Handle it in a static protected manner.

- (a) Obtain the Power Supply Distribution PWB (Nautel Part # NAPS58A) and Power Supply Mounting Deck (Nautel Part # 211-5318) from the Field Modification Kit.
- (b) Install 11 of the 12 pillars and washers retained in step 2.2 (h) in the PS Distribution Mounting Pillars positions shown in Figure 3. Install the chafe rail on the rear side edge.
- (c) While ensuring that all wires removed in step 2.2 (c) are clear of the deck area, install the Power Supply Mounting Deck to the transmitter chassis using the 12 M3 countersunk screws retained in step 2.2 (e). See Figure 3 for mounting locations for both scenarios.
- (d) Install the Power Supply Distribution PWB on its 11 mounting pillars (see Figures 2 and 3). Use hardware retained in step 2.2 (d) to secure the PWB (not all hardware is reused), using a 5.5-mm nut driver for nine M3 nuts, split and flat washers, and a 6-mm nut driver for two pillars near TB1 and TB2.
- (e) Connect ribbon cable plugs W2P2 and W4P2 and MTA connectors P7 and P8 to the Power Supply Distribution PWB.

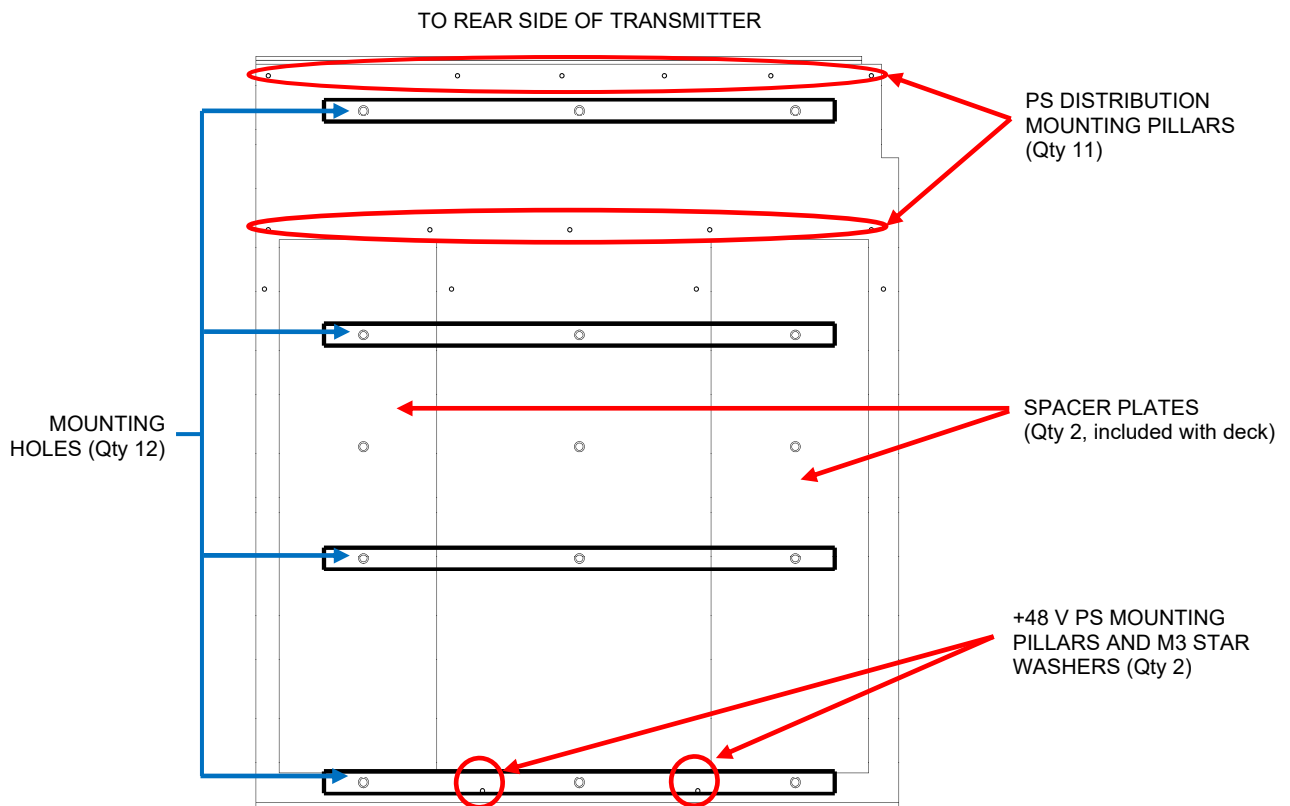

Figure 3: New Power Supply Mounting Deck



- (f) Connect the 17 wires (# 7 through 14 and 25 through 33) removed in step 2.2 (b) to terminal blocks TB1 through TB4 of the Power Supply Distribution PWB. Refer to Table 4.3, Wiring List – VS2.5 Transmitter of the Troubleshooting Manual for wiring details.
- Torque connections on TB1, TB3 and TB4 to 20 in-lbs (2.24 N-m).
 - Torque connections on TB2 to 6 in-lbs (0.67 N-m).
- (g) Re-install the cover over TB1 and TB2 using retained M3 screws.
- (h) Use a 6-mm nut driver to re-install the pillars retained in step 2.2 (g) on the Power Supply Mounting Deck, on top of new M3 star washers (Nautel Part # HMW10) from the Hardware Kit. See Figure 3 for +48 V Power Supply mounting pillar locations.

3.2 Exciter/Control PWB Re-Installation

- (a) While ensuring that exciter wiring, ribbon cable ferrite, and associated items are clear, re-install the exciter deck retained in step 2.1 (h) in the transmitter, by pushing it backward and down. Use five screws retained in 2.1 (f) to secure the exciter deck to the transmitter chassis (see Figure 1). Re-insert tyrap anchors in their original locations, noting there are additional tyrap anchors (Nautel Part # HAC61) in the Field Modification Kit.
- (b) Secure the Ribbon Cable Ferrite with a replacement tyrap, using Nautel Part # HT31 from the Field Modification Kit.

CAUTION!

The Exciter/Control PWB is static sensitive. Handle it in a static protected manner.

- (c) Re-install the Exciter/Control PWB (A1, Nautel Part # NAPE87*), following the steps outlined in Section 1 of the VS2.5 Troubleshooting Manual. See Figure 1 for location and orientation. If an Orban Inside card is installed on the Exciter/Control PWB, it can remain secured to the Exciter/Control PWB during installation.

3.3 Power Supply Module Installation

- (a) Obtain the two Power Supply Modules (Nautel part # UG132), Front Support Bracket (Nautel Part # 211-5314), two Rear Support Brackets (Nautel Part # 211-5315), and the Hardware Kit (Nautel Part # 211-5317) from the Field Modification Kit.

NOTE

When inserting Power Supply Modules, ensure the latch is in the closed/ locked position.

- (b) Install the new Power Supply Modules in the U1 and U3 positions of the transmitter (the middle position, U2, is no longer used) and slide them toward the rear of the transmitter to engage them with their mating connectors. The Power Supply Modules should be resting on their respective Spacer Plates (see Figure 3) when correctly positioned.
- (c) Install the Front Support Bracket on the front of the Power Supply Modules using the four M4 screws removed in Step 2.1 (b). The bracket is secured with two screws on each side of the transmitter. See Figure 4.
- (d) Install the two (2) Rear Support Brackets on the rear of the Power Supply Modules using the four (4) sets of M3 nuts and washers (Nautel Part #'s HMN02, HMW02 and HMW32), found in the Hardware Kit. See Figure 4.



- (e) Move the +48 V Power Supply Bracket and its wiring to its original position. Secure the +48 V Power Supply Bracket using the hardware [two (2) countersunk M4 screws and two (2) M3 screws] retained in step 2.2 (e). Install the M4 screws just above the front panel. Install the M3 screws on the pillars installed in step 3.1 (h).
- (f) Use provided tyrapas, as required, to secure wiring.
- (g) Install the VS2.5's top cover using hardware retained in step 2.1 (a).
- (h) Upgrade the software of the VS2.5 transmitter to VS SW 5.3.2. Refer to the VS2.5 Operations and Maintenance manual for instructions.
- (i) Obtain Information Sheet IS22001 and follow the procedure to initiate an exciter attenuation routine.
- (j) The modification is complete. Return the transmitter to proper operation.

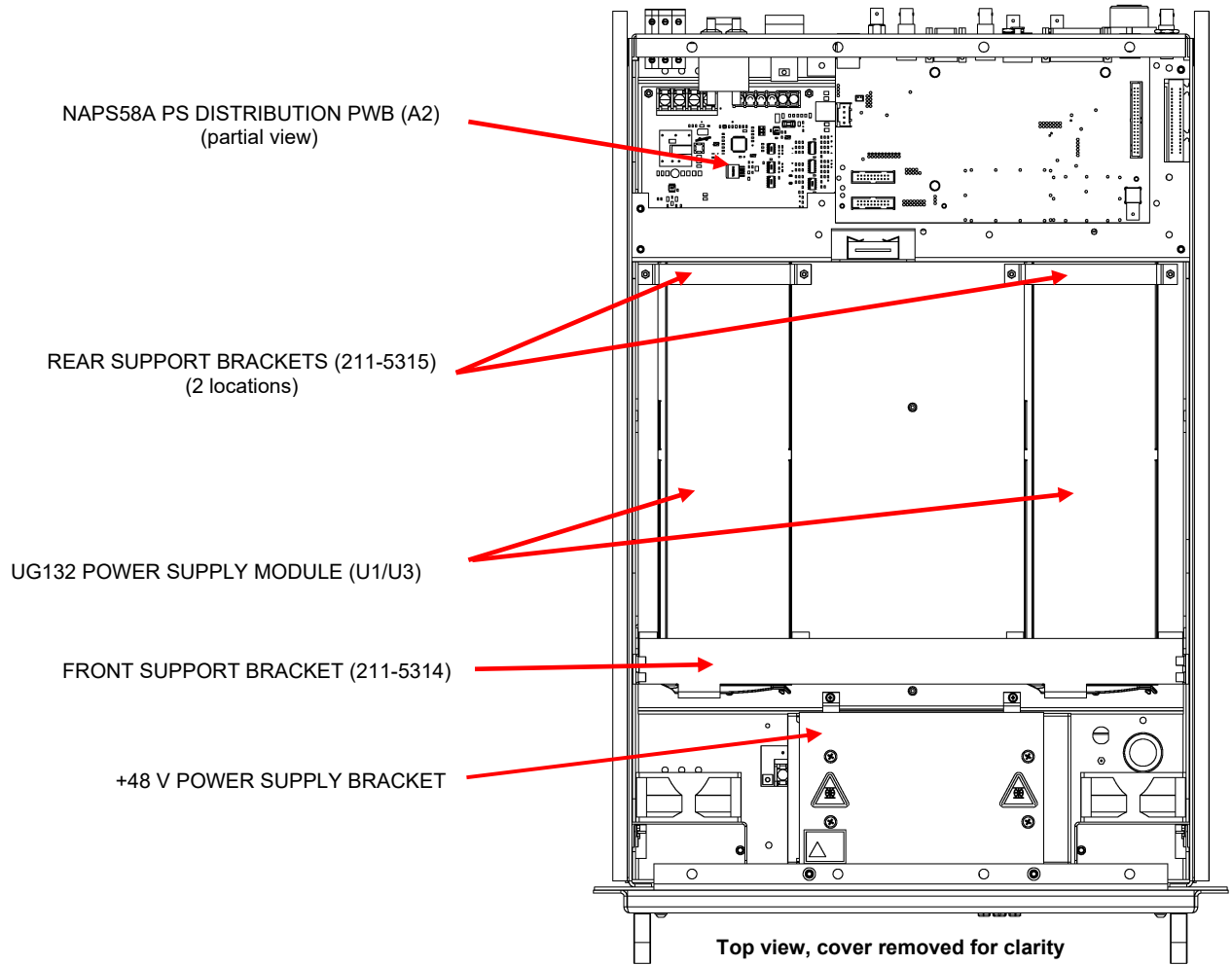

Figure 4: VS2.5 Top View with new PS Distribution PWB and Power Supply Modules

If you have any questions or require additional assistance, please contact Nautel's Customer Service Department at:

Telephone: 1-877-662-8835

Email: support@nautel.com



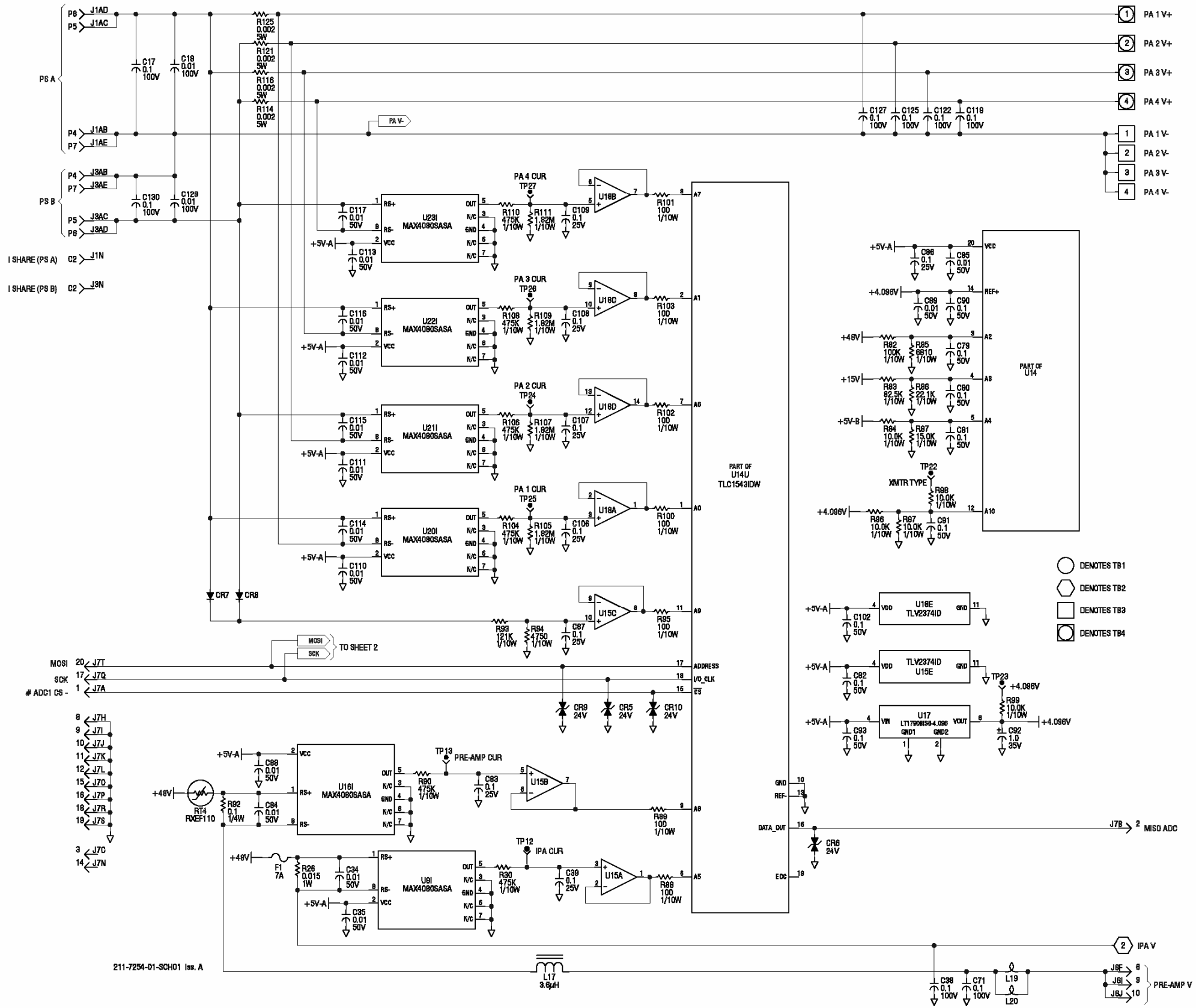

Electrical Schematic – NAPS58A Power Supply Distribution PWB

FM22007 – Manual Replacement Page

Not to Scale

Figure SD-4

Page 1 of 4



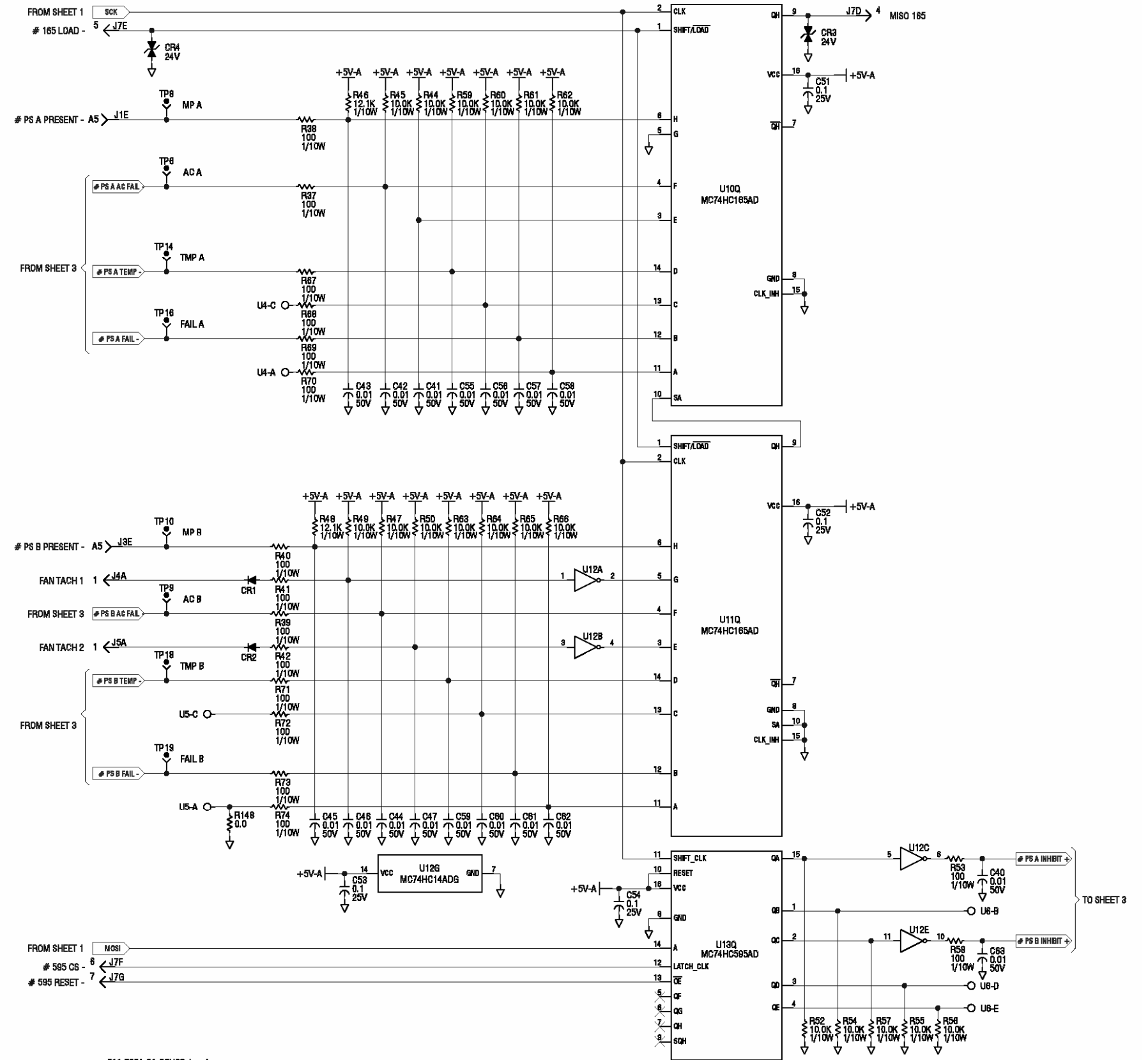

211-7254-01-SCH02 Iss. A



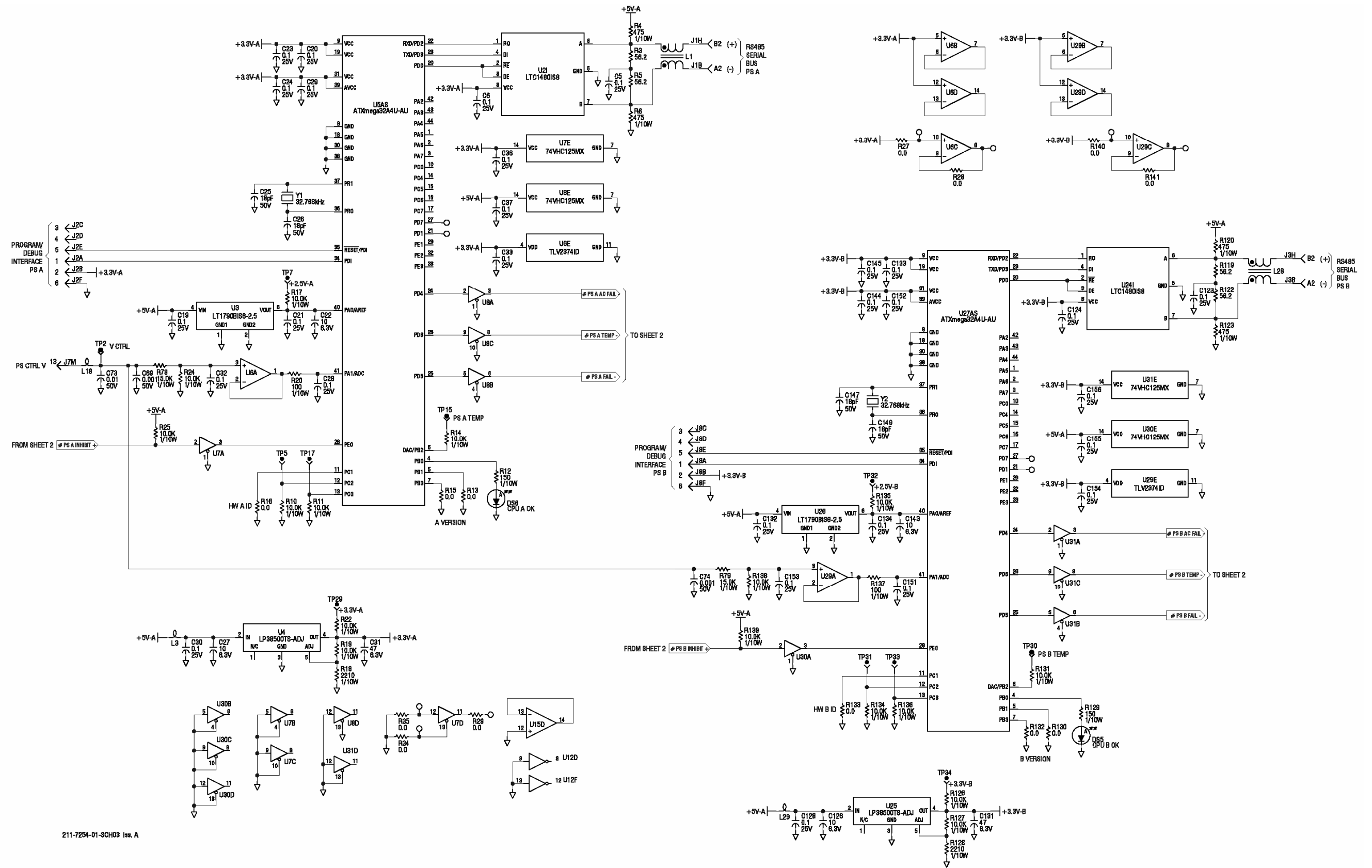

211-7254-01-SCH03 Iss. A



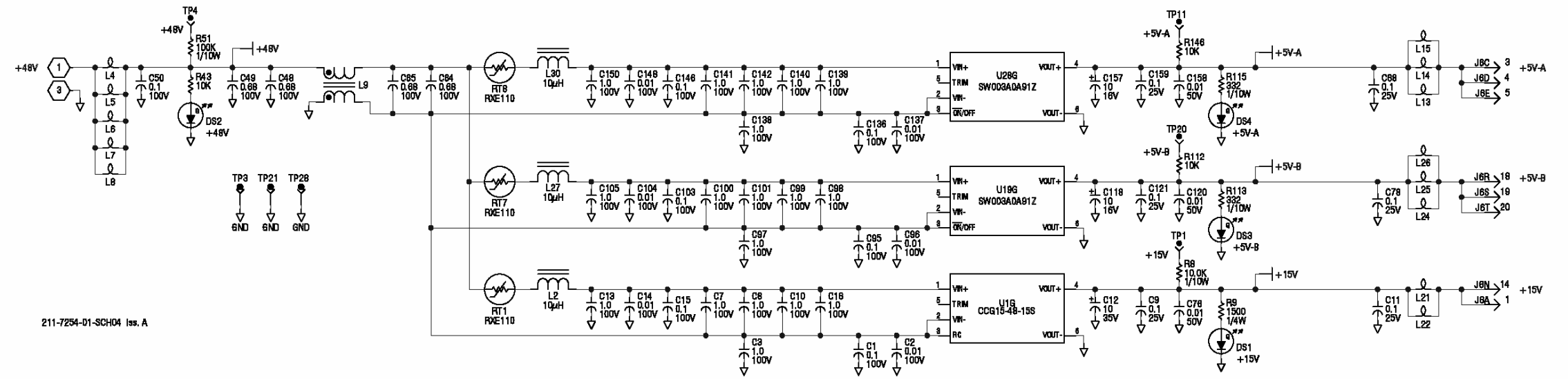
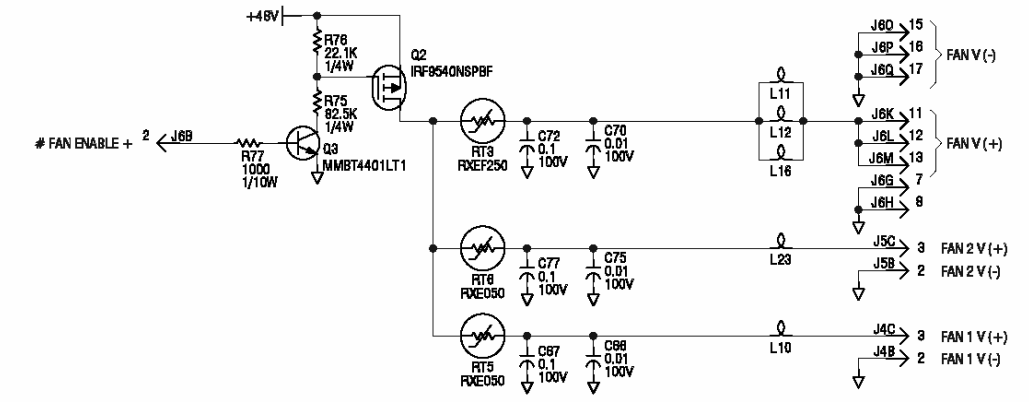
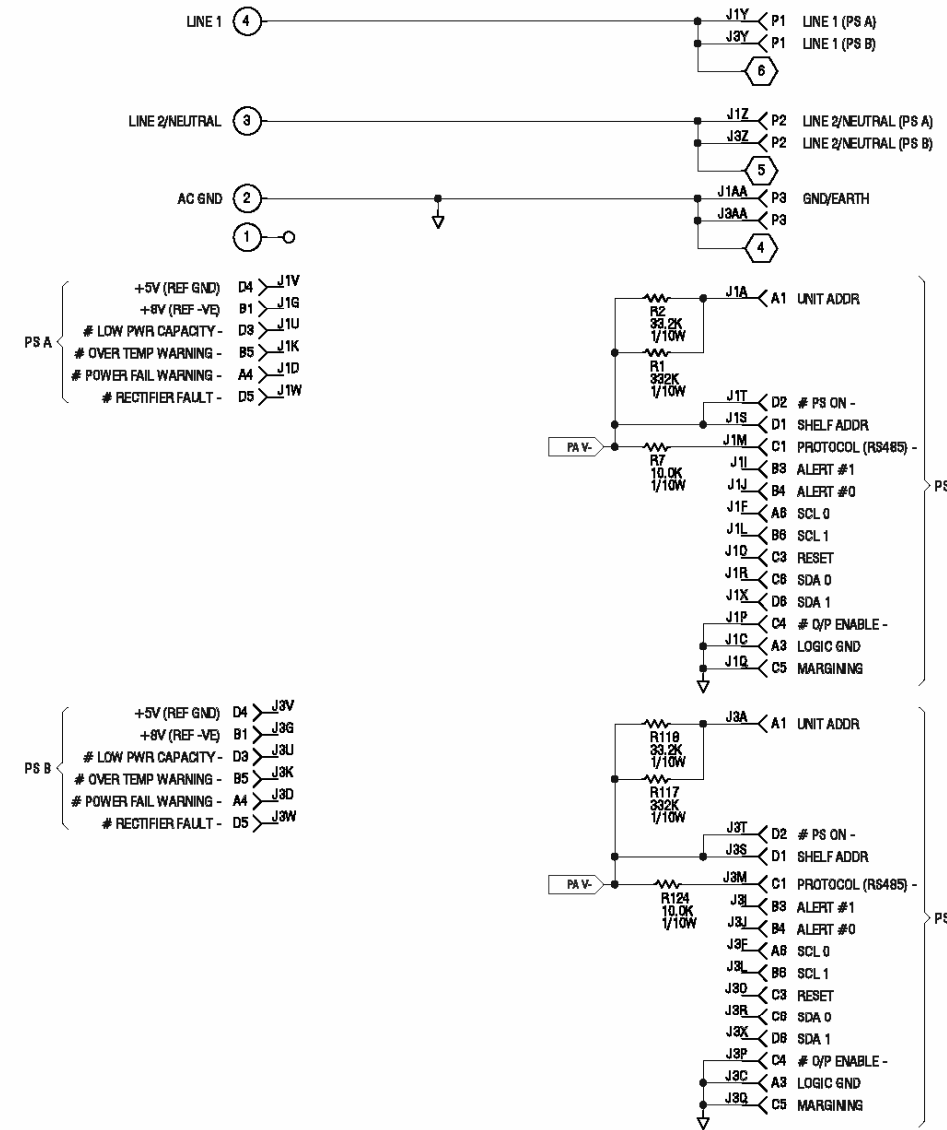

211-7254-01-SCH04 Iss. A



